

avercasso

CS ONE

COFFEE SORTER

User Manual



Safety Precautions

1. Before use, read all instructions and check the appliance and components.
2. Always use your appliance from a power outlet of the voltage marked on the appliance.
3. This appliance needs to be used with an air compressor and an air compressor filter.
4. Before use, make sure the air pipes are moisture-free.
5. Do not use this appliance for purpose other than coffee bean sorting. Incorrect operations may damage the appliance.
6. Do not operate until the touch panel is securely installed or locked in place.
7. Recommended for use on a stable platform at a height of 80 cm.
8. The appliance is heavy, please exercise caution when handling and moving for safety.
9. Keep clear of the cooling fan. Allow 10 cm of space from the wall.
10. Keep the children away from using the appliance.
11. Grasp the plug when plugging or unplugging, avoid pulling on the power cord.
12. Do not immerse the appliance into water or any liquid to avoid electric shock.
13. Do not use the appliance if the power cord or the appliance itself is broken.
14. Do not disassemble the appliance by yourself. Please contact avercasso technician, dealer or any other certificated technicians to conduct maintenance.
15. Turn the power off and remove the plug when the appliance is not in use and before cleaning.



This logo is intended to alert the users to the presence of un-insulated "dangerous voltage" within the product's enclosure that may be of sufficient magnitude to constitute a risk of electric shock to persons.



Before connecting the circuit and neutral, the protective conductor (PE) should be connected to the main protective grounding terminal first to avoid the risk of electric shock. Also, before connecting the main power supply, ensure that the PE is already connected to the main PE terminal to prevent electrical shock.

Caution

High touch current. Connect to earth before connecting to supply.
(Yellow/Green wire min. 14AWG)

Note

Installation of the protective earthing connection of the socket-outlet by a skilled person.

Attention

Contact à courant élevé, Reliez l'appareil à la terre avant de la connexion à l'alimentation en courant. (Câble jaune/vert min. 14AWG)

Remarque

L'installation du branchement de mise à la terre sécurisée d'une prise de courant par un professionnel qualifié.

DISCLAIMER

No warranty or representation, either expressed or implied, is made with respect to the contents of this documentation, its quality, performance, merchantability, or fitness for a particular purpose. Information presented in this documentation has been carefully checked for reliability; however, no responsibility is assumed for inaccuracies. The information contained in this documentation is subject to change without notice. In no event will AVer Information Inc. be liable for direct, indirect, special, incidental, or consequential damages arising out of the use or inability to use this product or documentation, even if advised of the possibility of such damages.

TRADEMARKS

“AVer” is a trademark owned by AVer Information Inc. Other trademarks used herein for description purpose only belong to each of their companies.

COPYRIGHT

© 2024 AVer Information Inc. All rights reserved. | January 25, 2024

All rights of this object belong to AVer Information Inc. Reproduced or transmitted in any form or by any means without the prior written permission of AVer Information Inc. is prohibited. All information or specifications are subject to change without prior notice.

Notice

Specifications Are Subject to Change without Prior Notice. The Information Contained Herein Is to Be Considered for Reference Only

More Help

For FAQs, technical support, software and user manual download, please visit:

<https://www.avercasso.com/en-us/coffee-sorter/cs-one>

Contact Information

Headquarters

AVer Information Inc.

<https://www.aver.com>

8F, No.157, Da-An Rd., Tucheng Dist., New Taipei City 23673, Taiwan

Tel: +886 (2) 2269 8535

USA Branch Office

AVer Information Inc., Americas

<https://www.averusa.com>

668 Mission Ct., Fremont, CA 94539, USA

Tel: +1 (408) 263 3828

Toll-free: +1 (877) 528 7824

Technical support: support.usa@aver.com

Europe Branch Office

AVer Information Europe B.V.

<https://www.avereurope.com>

Westblaak 134, 3012 KM, Rotterdam, The Netherlands

Tel: +31 (0) 10 7600 550

Technical support: eu.rma@aver.com

Japan Branch Office

アバー・インフォメーション株式会社

<https://jp.aver.com>

〒160-0023 日本東京都新宿区西新宿 3-2-26 立花新宿ビル 7 階

Tel: +81 (0) 3 5989 0290

テクニカル・サポート: <https://jp.aver.com/technical-support>

Vietnam Branch Office

Công ty TNHH AVer Information (Việt Nam)

Tầng 5, 596 Nguyễn Đình Chiểu, P.3, Quận 3,

Thành phố Hồ Chí Minh 700000, Việt Nam

Tel: +84 (0) 28 22 539 211

Contents

Unpacking Your Appliance	1
Overview	2
Package Contents.....	2
Parts Info	3
Dimension and Weight.....	5
Get Started	6
Installation	6
Set up Your CS One	7
Cleaning and Maintenance	8
AI Sorting System	9
First-time Setup.....	9
The Sorting Process	10
Add Sorting Modules	11
Coffee Bean Sorting History Report	12
System Settings	13
Parameter Settings.....	13
Interface Settings	14
Administrator Settings	15
Sorter Cleaning Settings	15
Issue Report	15
Sorter Information.....	16
Power off Your Appliance	16
The avercasso App	17
Download the avercasso App	17
Add and Delete CS One	17
Check and Filter Exception Notification	18

Notifications	19
Settings	20
Language	20
Troubleshooting	21
Specification	23

Unpacking Your Appliance

Hold tight on the handles and be cautious when moving your appliance.

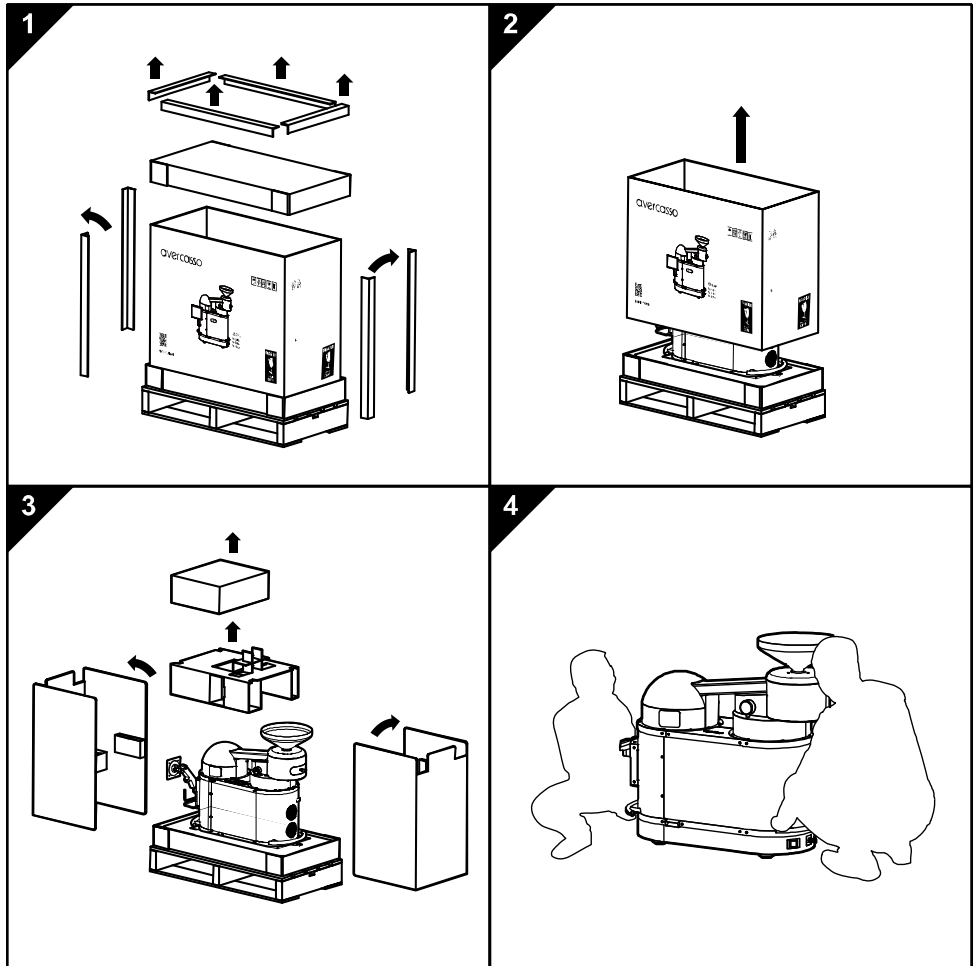

Overview

The CS One is equipped with an AI-powered 4K dual lens to effectively recognize and capture the defective beans.

Package Contents

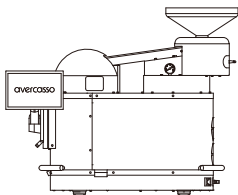

CS One
AI Coffee Green Bean
Sorter

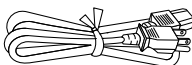

Power Cable (1.83 m)



Coffee Bean Gate
(For stop dropping beans
into the chute.)

Parts Info

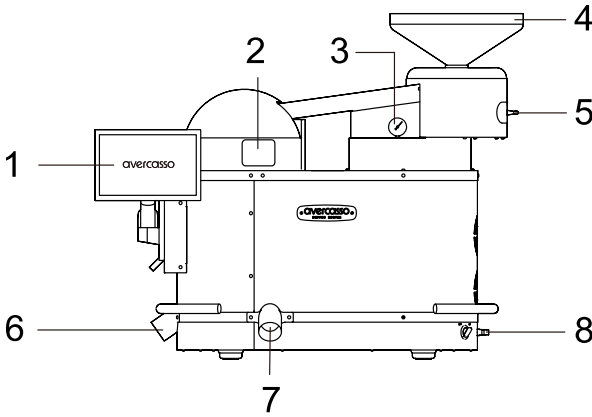

Front View

1. 10.1 inch Touch Panel
2. Recognition Module
Cleaning Window
3. Air Pressure Display
4. Bean Hopper
5. Dust Collector
6. Good Bean Outlet
7. Defective Bean Outlet
8. Air Pressure Inlet

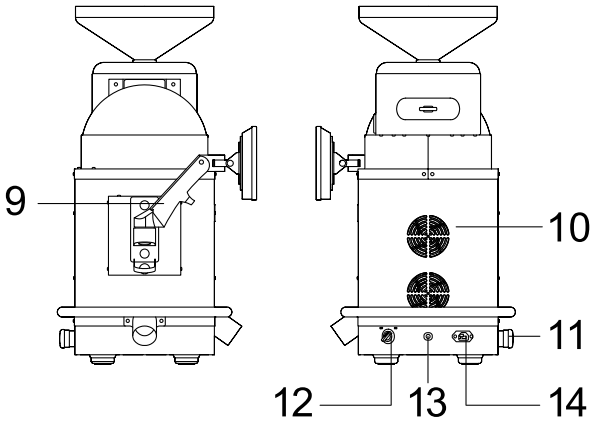

Side View

9. Swivel Screen Support
10. Cooling Fan
11. Emergency Button
12. Power Switch
13. Air Pressure Inlet
14. 6-8 kg/cm² (85-113 psi)
15. Power Input 110 V

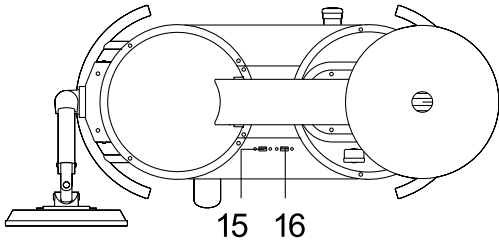

Top View

16. USB Input

17. Wi-Fi Receiver

Dimension and Weight

Appliance net weight: 50 kg (110.2 lb.).

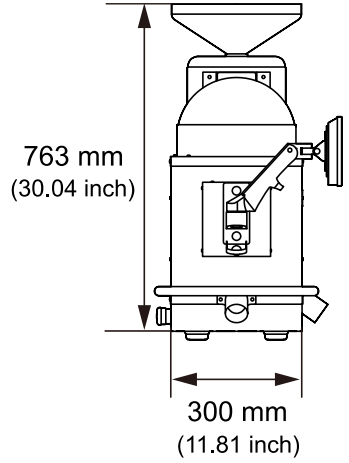
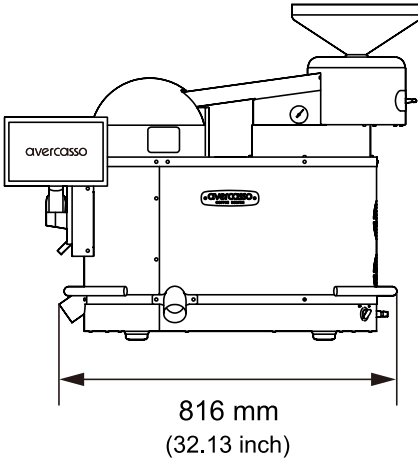

Get Started

Installation

1. Secure the touch panel onto the screen support.

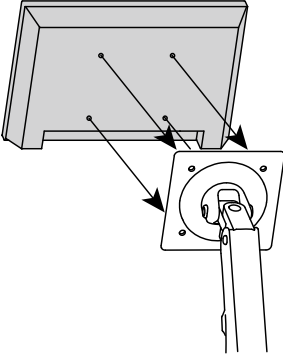

2. Connect the USB cable, HDMI cable and power cable to the touch panel.

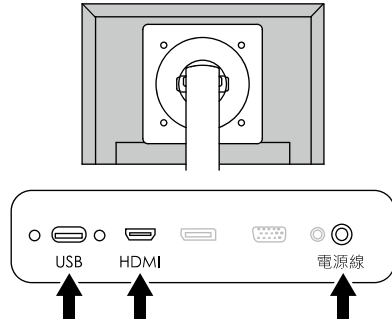

3. Connect oil-water separator to the air compressor and the air pressure outlet. Plug in the air compressor power cable. Use a pipe wider than 8 mm for the machine air pressure outlet.

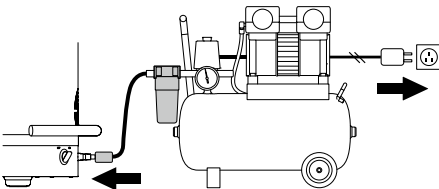



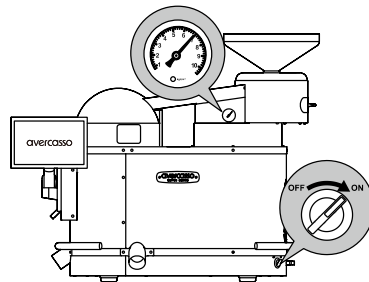



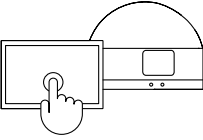

4. Check if the air pressure display shows around 6-8 kg/cm² (85~113 psi). Plug in the machine power cable, and turn the Power Switch to **ON** to power up.



Set up Your CS One

1. For first-time setup, follow the on-screen instruction to set up the system and the sorting module.



2. From the Home page  > **Sorting Module Database** , select and tap a sorting module from the Module Name list to apply a sorting module as needed.
3. Go back to the Home page  > tap the **Start** button  to start the sorting process.
4. To stop the sorting process, tap the **Pause** button  to pause, or tap the **Stop** button  to end the sorting process.
5. When the sorting process is finished, go to **Coffee Bean Sorting History Report**  to check the results.
6. To power off the appliance, tap the Power button  on the Home page to turn off the sorting system. For more information, please refer to <AI Sorting System> chapter.
7. When the sorting system is off, turn the Power Switch to OFF to power off the appliance.

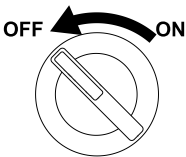

Cleaning and Maintenance

- For optimal performance, clean the bean hopper and sorting chute regularly after sorting. Use an air gun to clean the dust collector and the recognition module.
- Use a cleaning brush to clean the recognition module.

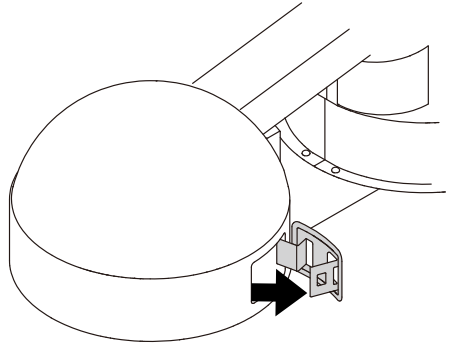
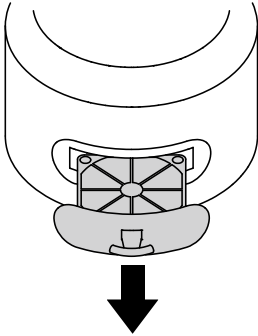

Important:

1. Do not immerse the appliance into water or any liquid to avoid electric shock.
2. Avoid using abrasives or steel scrubbers.
3. When cleaning with an air gun, avoid nozzle contact with the recognition module glass to prevent glass breakage.
4. Install accessories only after thorough drying after cleaning.

AI Sorting System

First-time Setup

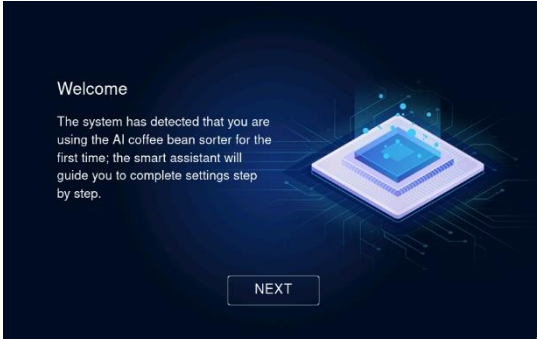

Setup Wizard

1. Select a system language.
2. Verify the licensing agreement and the privacy policy.
3. Set up the region and time zone.
4. Name your device for easy identification when connecting to other devices. Use uppercase and lowercase and numbers. No spaces or special symbols.
5. Set up a 4-digit password.

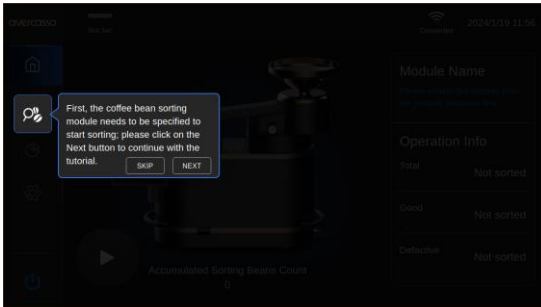



Setup a Sorting Module

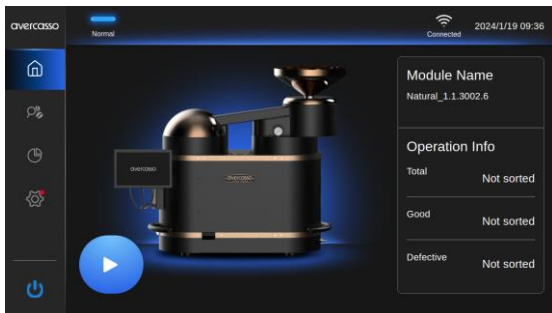

1. Go to **Sorting Module Database**

2. Select and tap a sorting module from the Module Name list to apply a sorting module as needed.

The Sorting Process



1. Make sure to connect your appliance to Wi-Fi. If you see  on the status bar at the top of the screen, tap the  icon and follow the on-screen instruction to establish a Wi-Fi connection.

2. Tap the Date and Time on the status bar to configure date and time.

3. From the Home page  > **Sorting Module Database** 

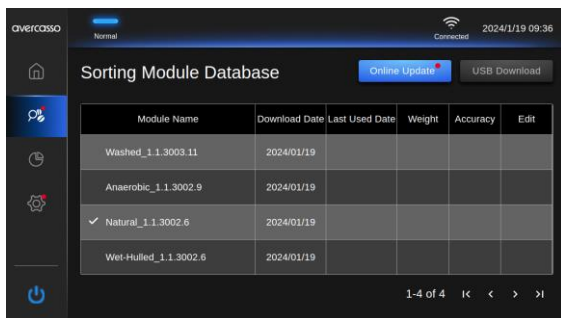

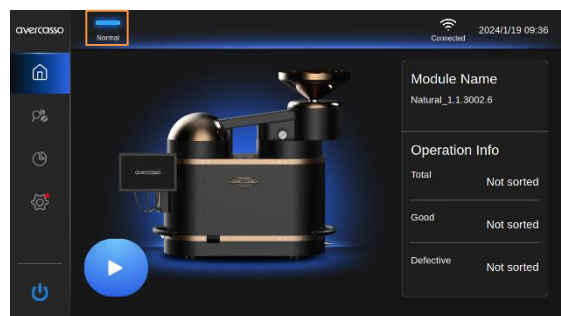

4. Tap the desired sorting module and confirm.

5. To check the applied sorting module, go to **Sorting Module Database**.  There will be a check by the applied sorting module.



6. When you see a blue light on the status bar, your appliance is ready to sort the beans.

7. Back to the Home page  and tap the **Start** button  to begin the sorting process.

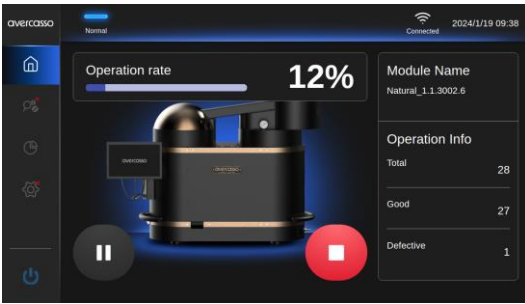

8. Follow the on-screen instruction to enter a sorting weight. You can check the operation rate on the Home page .
 - To skip entering the sorting weight and hide the operation rate, go to **System Setting** > **Interface Settings** > turn off the **Enable Complete Display Mode for the Sort Progress Bar on the Home page** setting.
9. To pause the sorting process, tap the Pause button .
10. To end the sorting process, tap the Stop button .
11. When the sorting process is completed, go to **Coffee Bean Sorting History Report** to check the sorting results.

Add Sorting Modules

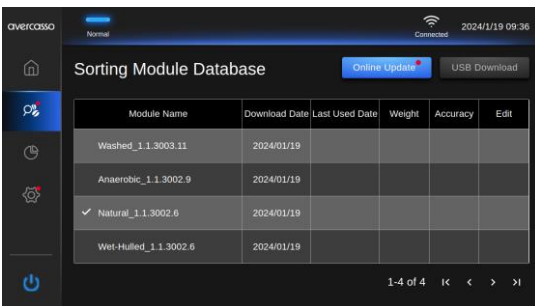

Add Sorting Modules

1. From the Home page , go to **Sorting Module Database** .
2. Select **Online Update** or **USB Download**.
 - **Online Update:** The system will search for suitable modules through Wi-Fi connection.
 - **USB Download:** Download new modules from USB if necessary.
3. A red dot indicates an available update.

Coffee Bean Sorting History Report

Module Name	Record Date	Accuracy	Edit
Anaerobic_1.1.3002.9	2024/01/19 09:39	0.0%	Export Defective Bean Images
Washed_1.1.3003.11	2024/01/19 09:39	14.3%	Export Defective Bean Images
Natural_1.1.3002.6	2024/01/19 09:38	2.9%	Export Defective Bean Images

View Sorting History Report

Go to **Coffee Bean Sorting History Report** to view all the sorting results.

Note: If the space is running out, the system will automatically delete the oldest history report to free up space.

Export CSV

Tap **EXPORT CSV** to export the sorting history report.

Export Defective Bean Images

1. Connect USB to the USB input.
2. Tap **Export Defective Bean Images**.

Delete History Report

1. Tap the Trash can button . The defective bean images of the report will be deleted at the same time.
2. Tap **DELETE ALL** to delete all history report.

System Settings

Parameter Settings

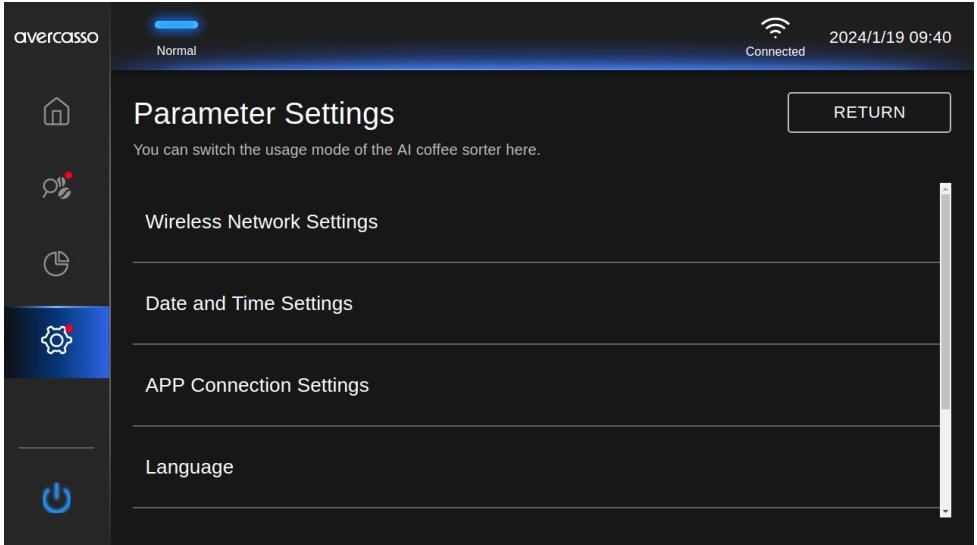

Item	Description
Wireless Network Settings	<ol style="list-style-type: none">Go to System Settings  > Parameter Settings > Wireless Network Settings.Turn on Enable Wi-Fi, select a Wi-Fi and enter then password.
Date and Time Settings	Tap CHANGE to configure date and time.
App Connection Settings	<ol style="list-style-type: none">Scan the iOS or Android QR Code on screen to download avercasso App. For more information, please refer to <The avercasso app>.Use the QR Code scanner in the avercasso App to scan the sorter QR code on screen to add your appliance in the App.

Select a language from the drop-down list:

Language

- 繁體中文
- English

Select **UPDATED VIA USB PORT** or **ONLINE UPDATE**.

System Update

1. **UPDATED VIA USB PORT:** Update by connecting USB to the USB port if necessary.
2. **ONLINE UPDATE:** The system will update through Wi-Fi connection.

Reset Sorter

Tap to reset all settings to factory default. (The sorting module and the machine firmware will be kept).

Interface Settings

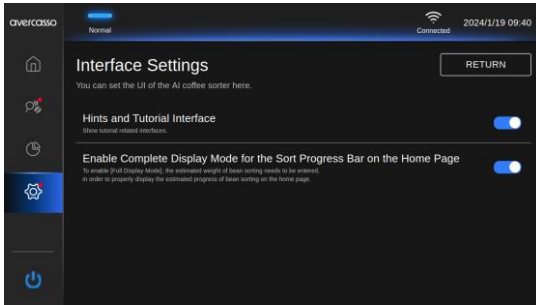

- Turn on or off the **Hints and Tutorial Interface** setting.
- Turn on or off the **Enable Complete Display Mode for the Sorting Process Bar on the Home page** setting. When it's off, you can skip entering sorting bean weight and hide the operation rate on the Home page .

Administrator Settings

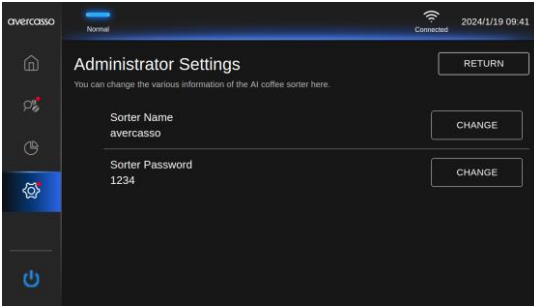

Tap **CHANGE** to edit the sorter name and password.

- Name your device for easy identification when connecting to other devices. Use uppercase and lowercase and numbers. No spaces or special symbols.
- Set up a 4-digit password.

Sorter Cleaning Settings

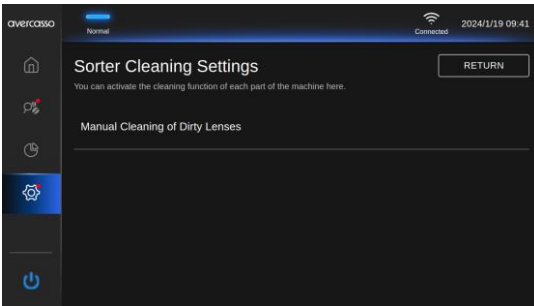

Tap **Manual Cleaning of Dirty Lenses**, and follow the on-screen instruction.

Issue Report

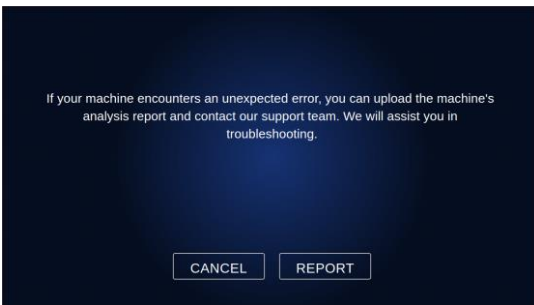

Tap **REPORT** to upload the analysis report of the machine for troubleshooting.

Sorter Information

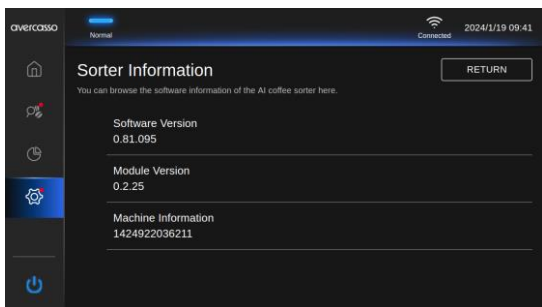

View software version, module version and machine information.

Power off Your Appliance



1. Tap the **Power** Button  on the Home page to turn of the sorting system.
2. After the sorting system is off, turn the Power Switch to **OFF** to power off your appliance.

The avercasso App

View current sorting progress and receive notifications on your smartphone with the avercasso App.

Download the avercasso App

iPhone



App Store
iOS 13.0 or later

Android





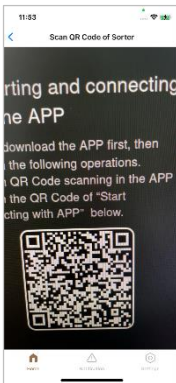

Google Play
Android 6.0 or later

Add and Delete CS One



Add CS One

1. Make sure your smartphone and your appliance are connected to the same Wi-Fi network.
2. Open the avercasso App.
3. For first-time setup, tap **Add Device** on the Home page 
4. Scan the QR Code on the appliance touch panel. (Go to **System Settings**  > **Parameter Settings** > **App Connection Settings**)
5. View all the added appliances in the **AI Coffee Bean Sorter List**.
 -  Green : Online
 -  Grey : Offline
 - The avercasso App will remember the added appliances and detect if the appliances are online.
6. Tap the device on the list to view the sorting details.

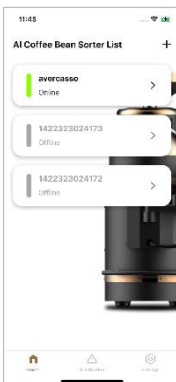



Delete the Paired CS One

1. Long press on the appliance that you want to delete in the **AI Coffee Bean Sorter List**.
2. Tap **Delete** > **Confirm**.

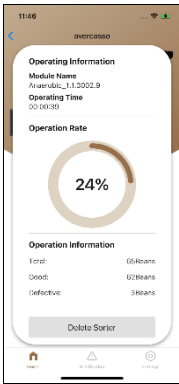



Delete the Online CS One

1. Select and tap the online appliance that you want to delete in the **AI Coffee Bean Sorter List**.
2. Scroll through the **Operation Information** card and tap **Delete Sorter**.

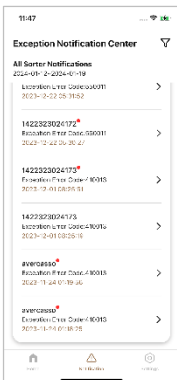
Check and Filter Exception Notification



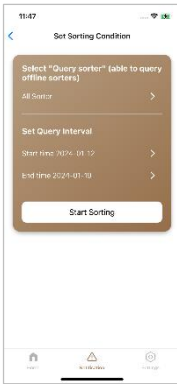

View Exception Notification

1. Go to Notification .
2. Tap the right arrow  on the exception notification to view error details, and follow the error description to solve the problem.
3. A red dot indicates the unread exception notification.



Set Sorting Condition

1. Go to Notification .
2. Tap the filter icon  on the top right corner to filter notifications based on the appliances or the date.
 - Tap the right arrow of **Select "Query sorter"** to select appliances.
 - Tap **Start time** and **End time** to set query interval.

Notifications

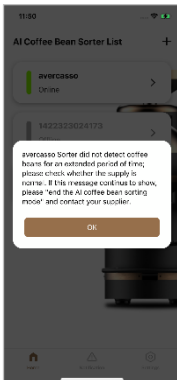



When the App is Open

Tap **OK** on the notification to open Notification page  in the App.



When the App is Closed (Running in the Background)

- iOS: Tap the on-screen notification to open Notification page  in the App.
- Android: Tap the on-screen notification to open the Home page  in the App. The notification will not be saved in the **Exception Notification Center** .

Settings

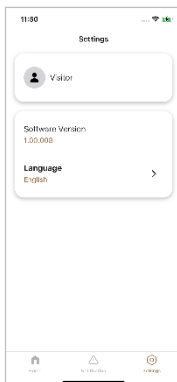

1. Go to **Settings** .
2. Check user information, software version and system language.

Language

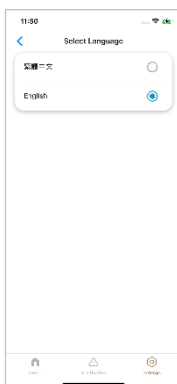

1. Go to **Settings**  > **Language**.
2. Select a system language.
 - 繁體中文
 - English

Troubleshooting

Q: Why is the sorting speed so slow?

A:

- Follow the on-screen instruction when you see a warning pop-up shows: "Bean stuck in the putter."
- Check and clean the bean hopper if it is stuck.

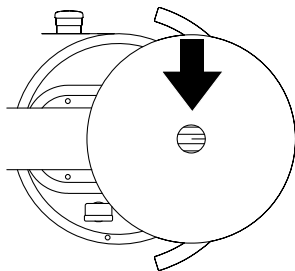

Q: Why is there no display on the touch panel?

A: Please check if you connected the USB, HDMI and DC Cable of the touch panel.

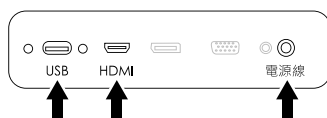
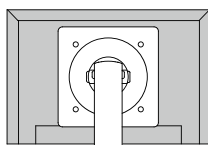

Q: Why hasn't the defective beans been ejected?

A: The air pressure input should be around 6-8 kg/cm² (85~113 psi). Please check the air pressure display.

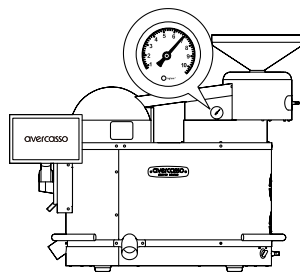

Q: Why does the machine frequently enter cleaning mode so?

A:

- Please check and clean the dust collector.
- If you've already cleaned the dust collector but the problem is not solved, please contact us.

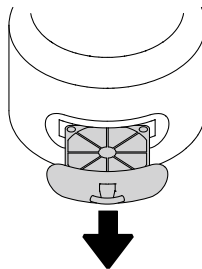

Q: Why is the CS One sorting accuracy decreasing?

A: Please check the air compressor oil-water separator, and drain the air compressor regularly.

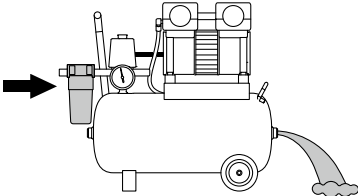

Specification

Model Name	CS One	I/O Port	USB 2.0 Type A
Model Color	Bronze*	Connectivity	Wi-Fi Dongle (2.4 GHz/5 GHz)
AI Module	Natural (Dry) / Washed (Wet)** More modules coming soon.	System Update	OTA (Over-The-Air Technology)
Product Efficiency	5kg (11lb.) / hr	Dimension	37.4(L) x 11.81(W) x 30.39(H) inch
Hopper Volume	Max 2.5kg (5.5lb.)	Weight	110.23 lb. (Net Weight) / 133.82 lb. (Gross Weight)
Air Pressure	6–8 kg / cm ² (85–114 psi)	Power Supply	AC 100-240 V
OSD	10.1 inch LCD Touch Panel	Operating/ Standby Power	≤0.1 kWh / ≤0.05 kWh
Processor	AVerMedia AI Box equips NVIDIA® module	Ambient Humidity	20-80% RH (Optimal 40-60%)
Algorithm	AVer AI-BeanFace	Ambient Temperature	0–40 °C (0-104 °F)
Storage	256 GB	Warranty	1 year

*On-demand custom colors available.

**Purchase additional processing modules as needed.

***Product specifications are subject to change without notice.

****The CS One is designer to work with an air compressor.

Emergency Switch Information

Name	Brand	Model Name
AC Switch	IDEC CORPORATION	LBW7S-2T2, LB Series YW1S-2E20, YW Series CW1S-2E20, CW Series
EMO Bottom	IDEC CORPORATION	AB6E-3BV01PTRH, X6 Series, AB6E YW1B-V4E01R, YW Series



Official Website



averCASSO

Aver

©2024 Aver Information Inc. All rights reserved.
All brand names and logos are trademarks of their respective companies.

www.avercasso.com



Distributor/Dealer

