

# CS One AI Coffee Green Bean Sorter

## Quick Start Guide

### Unpacking Your Appliance

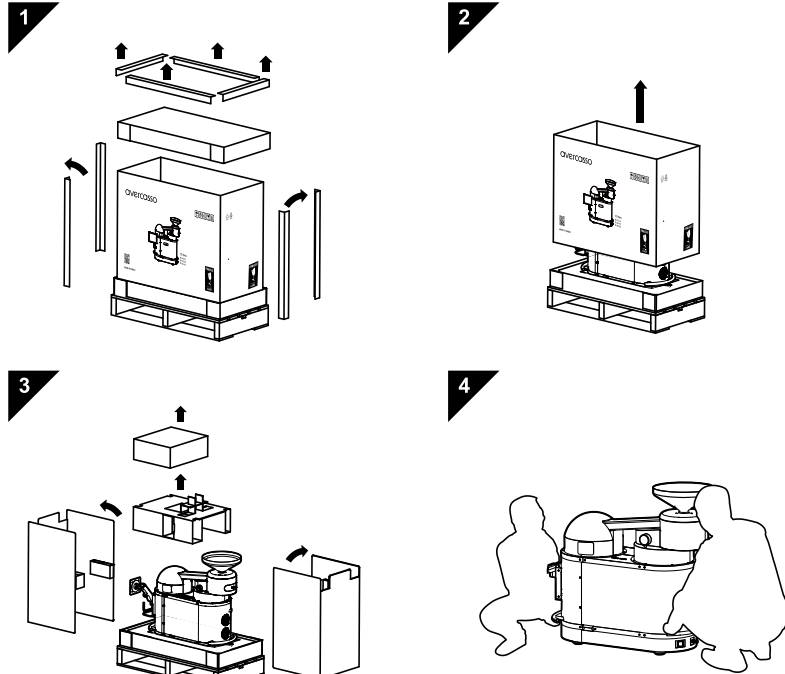

### Package Content

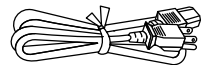

Power Cable (1.83 m)

P/N: 300ACG30-EN6

### Overview

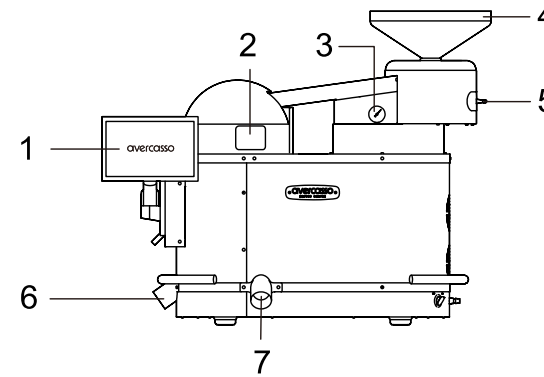

#### Front View

1. 10.1 inch Touch Panel
2. Recognition Module Cleaning Window
3. Air Pressure Display
4. Bean Hopper
5. Dust Collector
6. Good Bean Outlet
7. Defective Bean Outlet

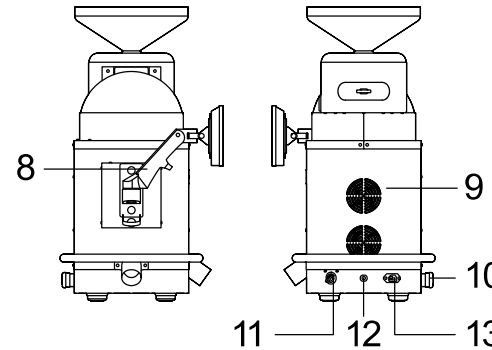

#### Side View

8. Swivel Screen Support
9. Cooling Fan
10. Emergency Button
11. Power Switch
12. Air Pressure Inlet  
6–8 kg/cm<sup>2</sup> (85–114 psi)
13. Power Input 110 V

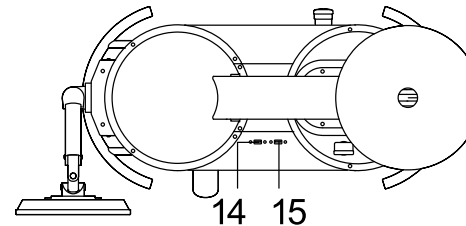

#### Top View

14. USB Input
15. Wi-Fi Receiver

## Dimension and Weight

Appliance net weight: 50 kg (110.2 lb.).

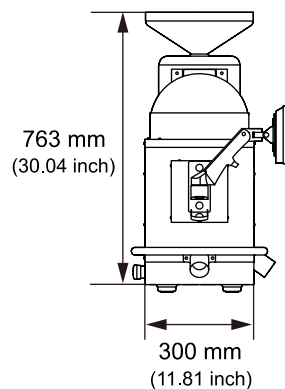
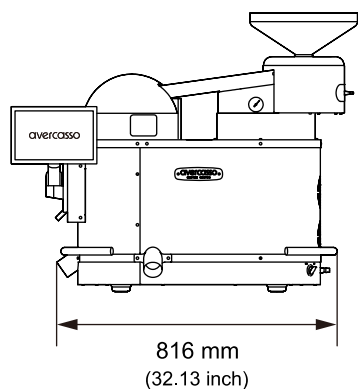

## Installation

1. Secure the touch panel onto the screen support.

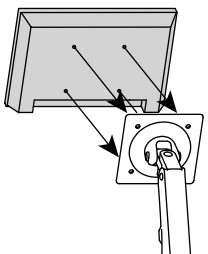

2. Connect the USB cable, HDMI cable and power cable to the touch panel.

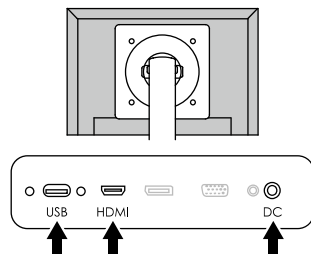

3. Connect oil-water separator to the air compressor and the air pressure outlet. Plug in the air compressor power cable. Use a pipe wider than 8 mm for the machine air pressure outlet.

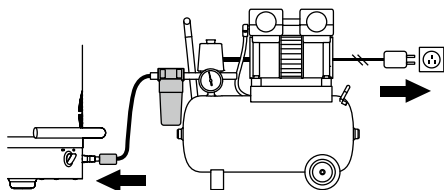

4. Check if the air pressure display shows around 6–8 kg/cm<sup>2</sup> (85–114 psi). Plug in the machine power cable, and turn the Power Switch to **ON** to power up.

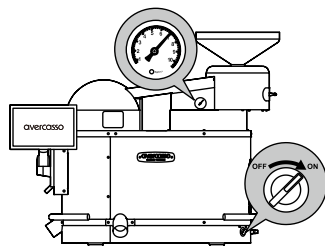

## Cleaning and Maintenance

- After sorting, clean the bean hopper and sorting chute regularly. Use an air gun to clean the dust collector and the recognition module.
- Use a cleaning brush to clean the recognition module.

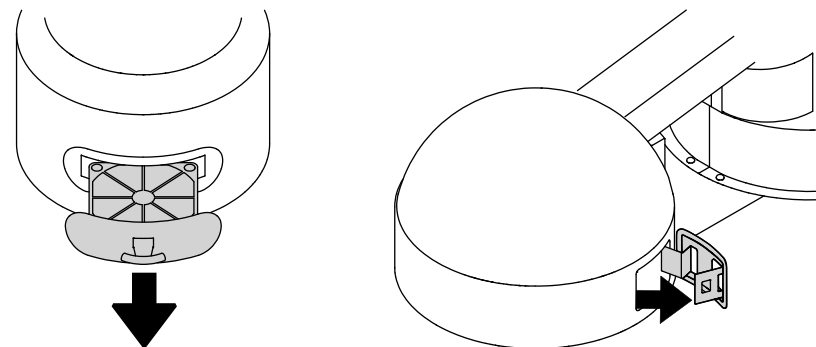

### Important:

1. Do not immerse the appliance into water or any liquid to avoid electric shock.
2. Avoid using abrasives or steel scrubbers.
3. When cleaning with an air gun, avoid nozzle contact with the recognition module glass to prevent glass breakage.
4. Install accessories only after thorough drying after cleaning.

## Troubleshooting

**Q: Why does the sorting speed slow down?**

**A:**

- Follow the on-screen instruction when you see a warning pop-up shows: "Bean stuck in the putter."
- Check and clean the bean hopper if it is stuck.

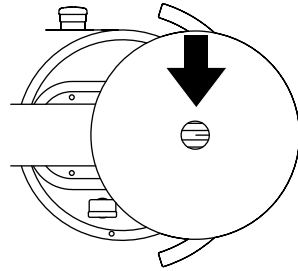

**Q: Why is there no display on the touch panel?**

**A:** Please check if you connect the USB, HDMI and DC Cable of the touch panel.

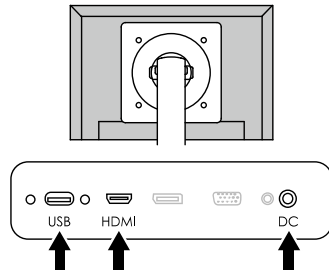

**Q: Why hasn't the defective beans been ejected?**

**A:** The air pressure input should be around 6–8 kg/cm<sup>2</sup> (85–114 psi). Please check the air pressure display.

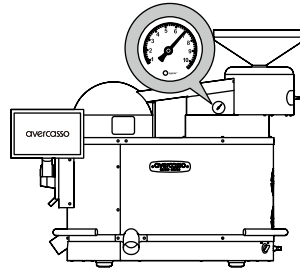

**Q: Why does the machine frequently enter cleaning mode so?**

**A:**

- Please check and clean the dust collector.
- If you've already cleaned the dust collector but the problem is not solved, please contact us.

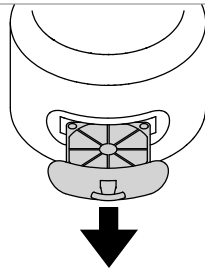

## Specification

<b>Model Name</b>	CS One	<b>I/O Port</b>	USB 2.0 Type A
<b>Model Color</b>	Bronze*	<b>Connectivity</b>	Wi-Fi Dongle (2.4 GHz/5 GHz)
<b>AI Module</b>	Natural (Dry) / Washed (Wet)** More modules coming soon.	<b>System Update</b>	OTA (Over-The-Air Technology)
<b>Product Efficiency</b>	5kg (11lb.) / hr	<b>Dimension</b>	37.4(L) x 11.81(W) x 30.39(H) inch
<b>Hopper Volume</b>	Max 2.5kg (5.5lb.)	<b>Weight</b>	110.23 lb. (Net Weight) / 133.82 lb. (Gross Weight)
<b>Air Pressure</b>	6–8 kg / cm <sup>2</sup> (85–114 psi)	<b>Power Supply</b>	AC 100–240 V
<b>OSD</b>	10.1 inch LCD Touch Panel	<b>Operating/ Standby Power</b>	≤0.1 kWh / ≤0.05 kWh
<b>Processor</b>	AVerMedia AI Box equips NVIDIA® module	<b>Ambient Humidity</b>	20–80% RH (Optimal 40–60%)
<b>Algorithm</b>	AVer AI–BeanFace	<b>Ambient Temperature</b>	0–40 °C (0–104 °F)
<b>Storage</b>	256 GB	<b>Warranty</b>	1 year

\*On-demand custom colors available.

\*\*Purchase additional processing modules as needed.

\*\*\*Product specifications are subject to change without notice.

\*\*\*\*The CS One is designer to work with an air compressor.

For more information, please refer to the <CS One User Manual>.

## Safety Precautions

1. Before use, read all instructions and check the appliance and components.
2. Always use your appliance from a power outlet of the voltage marked on the appliance.
3. Before use, make sure the air pipes are moisture-free.
4. Do not use this appliance for purpose other than coffee bean sorting. Incorrect operations may damage the appliance.
5. Do not operate until the touch panel is securely installed or locked in place.
6. Recommended for use on a stable platform at a height of 80 cm.
7. The appliance is heavy, please exercise caution when handling and moving for safety.
8. Keep clear of the cooling fan. Allow 10 cm of space from the wall.
9. Keep the children away from using the appliance.
10. Grasp the plug when plugging or unplugging, avoid pulling on the power cord.
11. Do not use the appliance if the power cord or the appliance itself is broken.
12. Do not disassemble the appliance by yourself. Please contact avercasso technician, dealer or any other certificated technicians to conduct maintenance.
13. Turn the power off and remove the plug when the appliance is not in use for a long time and before cleaning.



This logo is intended to alert the users to the presence of un-insulated "dangerous voltage" within the product's enclosure that may be of sufficient magnitude to constitute a risk of electric shock to persons.



Before connecting the circuit and neutral, the protective conductor (PE) should be connected to the main protective grounding terminal first to avoid the risk of electric shock. Also, before connecting the main power supply, ensure that the PE is already connected to the main PE terminal to prevent electrical shock.

### Caution

High touch current. Connect to earth before connecting to supply.  
(Yellow/Green wire min. 14AWG)

### Note

Installation of the protective earthing connection of the socket-outlet by a skilled person.

### Attention

Contact à courant élevé, Reliez l'appareil à la terre avant de la connexion à l'alimentation en courant. (Câble jaune/vert min. 14AWG)

### Remarque

L'installation du branchement de mise à la terre sécurisée d'une prise de courant par un professionnel qualifié.

### COPYRIGHT

© 2024 AVer Information Inc. All rights reserved. | January 25, 2024  
The information contained in this documentation is subject to change without notice.

### Contact Information

#### Headquarters

AVer Information Inc.  
<https://www.aver.com>  
8F, No.157, Da-An Rd.  
Tucheng Dist., New Taipei City  
Taiwan  
Tel: +886 (2) 2269 8535

#### USA Branch Office

AVer Information Inc.  
<https://www.averusa.com>  
668 Mission Ct.  
Fremont, CA 94539, USA  
Tel: +1 (408) 263 3828  
Toll-free: +1 (877) 528 7824  
Technical support:  
[support.usa@aver.com](mailto:support.usa@aver.com)

#### Europe Branch Office

AVer Information Europe B.V.  
<https://www.avereurope.com>  
Westblaak 134, 3012KM,  
Rotterdam, The Netherlands  
Tel: +31 (0) 10 7600 550  
Technical support:  
[eu.rma@aver.com](mailto:eu.rma@aver.com)

#### Japan Branch Office

アバー・インフォメーション株式会社  
<https://jp.aver.com>  
〒160-0023 日本東京都新宿区西新宿 3-  
2-26 立花新宿ビル 7 階  
Tel: +81 (0) 3 5989 0290  
テクニカル・サポート:  
<https://jp.aver.com/technical-support>

#### Vietnam Branch Office

Công ty TNHH AVer  
Information (Việt Nam)  
Tầng 5, 596 Nguyễn Đình  
Chiểu, P.3, Quận 3, Thành phố  
Hồ Chí Minh 700000, Việt Nam  
Tel: +84 (0)28 22 539 211

