

Official-Website

CS ONE

COFFEE SORTER

AVer

©2024 AVer Information Inc. All rights reserved.
All brand names and logos are trademarks of their respective companies.

www.avercasso.com



Distributor / Dealer



Specifically Crafted for



Roasters

●● Assist specialty roasters dedicated to crafting flavorful and healthy coffee by removing defective beans prior to roasting.



Farmers

●● Support coffee farmers in carefully sorting and eliminating defective beans to improve the overall quality and value of green coffee beans.



Traders

●● Ideal inspection tool and quality guardian at sampling for committed coffee traders ensuring top-quality green beans.



Advisors

●● Enhance green grading inspections with efficient, data-driven approaches for precise analysis.



Identify and Remove SCA-Classified Primary and Secondary Defects



▶ Good bean recognition rate exceeding

99%

AI-Powered 4K Dual Lens



Effective capturing of all green coffee beans.

AI Precision, Coffee Perfection

Automation

●● Load beans, choose your sorting method, and begin sorting! Streamlined and efficient sorting at the touch of a button.

Exclusive Data Report

●● Provide invaluable sorting report that calculates green coffee defects, bean by bean.

Coffee Bean Sorting Report

Module Name:
Washed_1.1.3003.11

Total:	62 Beans
Good:	49 Beans
Defective:	13 Beans
Start Time:	2023/12/21 14:59
End Time:	2023/12/21 15:01

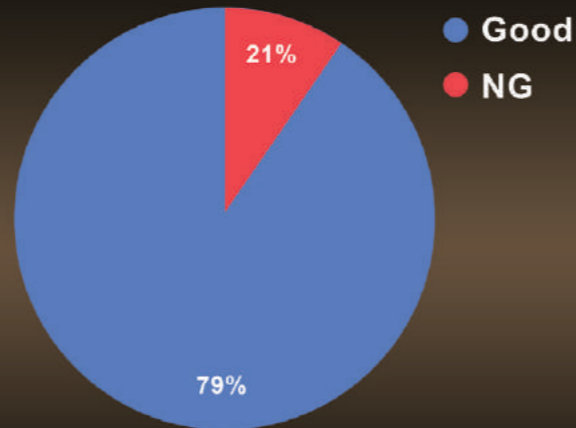

CLOSE

AI Processing

●● Customizable proprietary AI algorithm to solve all your bean sorting challenges.



Easy to Use



Intuitive Interface

● ● Simple operation via touch screen.

System Update

● ● Update latest software and system through OTA.

Mobile App Support

● ● Track your bean sorting and report issues in real-time with our mobile app.



Requires iOS 15.0 or above



Requires Android 12.0 or above



Easy Maintenance

●● Automated dust removal and simple manual cleaning for hassle-free maintenance.

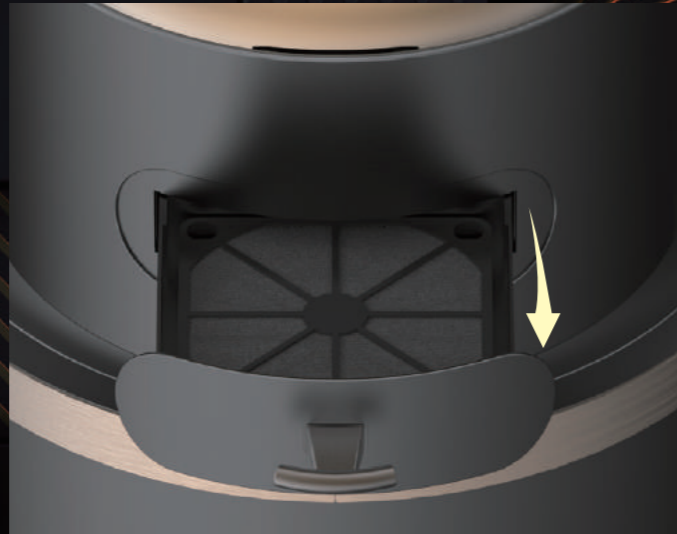

Ergonomic Friendly

●● Weighing a mere 50kg, CS One can be effortlessly moved with its specially designed handles.



Consumable-Free

●● Embrace Sustainability: no additional consumables needed post-purchase, ensuring a lasting and eco-friendly product experience.





Specifications

Model Name	CS One	I/O Port	USB 2.0 Type A
Model Color	Bronze Gold*	Connectivity	Wi-Fi Dongle (2.4GHz/5GHz)
Process Program	Natural (Dry), Washed (Wet)**	System Update	OTA (Over-The-Air Technology)
Sorting Speed	5 kg/hr (11 lb/hr)	Dimension	950(L) x 300(W) x 772(H) mm 37.4(L) x 11.81(W) x 30.39(H) inch
Hopper Volume	max. 2.5 kg (5.5 lbs)	Weight	50 kg (Net) / 60.7kg (Gross) 110.2 lbs (Net) / 133.8 lbs (Gross)
Air Pressure	6-8 kg/cm ² (85-114 psi)	Power Supply	AC 100-240V
OSD	10.1-inch LCD Touch Panel	Operating / Standby Power	≤ 0.1 kWh / ≤ 0.05 kWh
Processor	AVerMedia AI Box equips NVIDIA® module	Ambient Humidity	20-80% RH
Algorithm	AVer AI-BeanFace	Ambient Temperature	0-40 °C (0-104 °F)
Storage	256 GB	Warranty	1 Year Standard

* On-Demand Custom Colors Available

** Explore and acquire additional sorting processing modules as needed.

*** Product specifications are subject to change without notice

**** The CS One is designed to work with an air compressor.

Dimension and Package

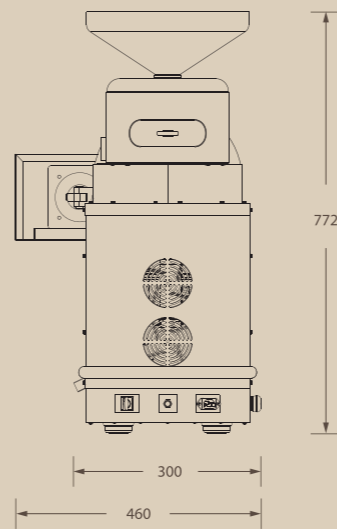
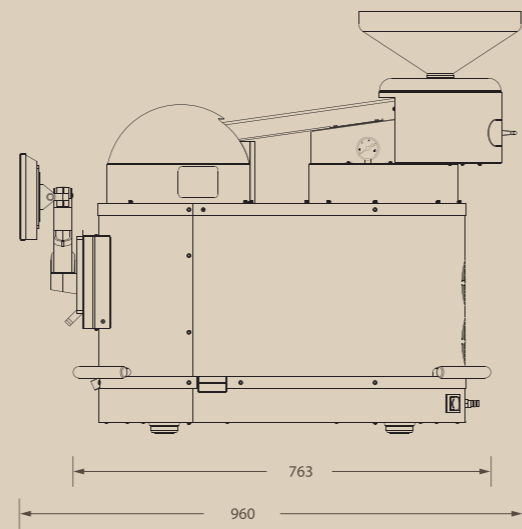
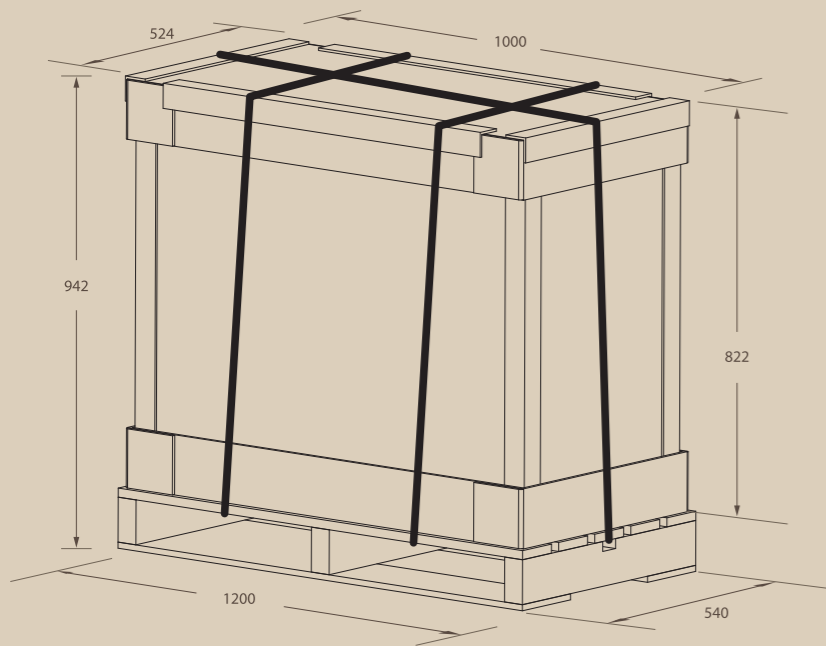

*Measurements are in millimeters (mm) for precision



This machine weighs 50kg. When moving, please firmly grip the handles on both sides and pay attention to safety.

